

GEHL®

RS SERIES TELESCOPIC HANDLERS

RS5-19 | RS6-34 | RS6-42 | RS8-42 | RS8-44 | RS10-44 | RS10-55 | RS12-42





In 1859, an agricultural implement company, housed in a blacksmith shop, was started in West Bend, Wisconsin. From these humble beginnings, the Gehl brand has become a major force in the compact equipment industry worldwide.



providing an
exceptional
experience

Since the beginning, Gehl has focused on providing solutions to our customer's needs by building quality, reliable products. With a long history of reliability and innovation, Gehl is responsive to the equipment and service needs of our customers.

With modern compact equipment manufacturing facilities in Yankton and Madison, South Dakota, and a state-of-the-art research and design facility in West Bend, Wisconsin, Gehl ensures that they are equipped with the finest in technology, tools and materials. And our top corps of engineers are skilled in designing and enhancing high-quality machines to fit the specific needs of our customers. Our equipment is modern in design and performance, but not too complicated to operate or service.

And when you purchase a piece of Gehl equipment, you have an entire organization behind you and your business. When you need support, whether it be financing, parts or service, know that Gehl will be there to provide an exceptional experience. We continually strive to preserve the level of personalized attention that Gehl began with in 1859.

GEHL

REACHING NEW HEIGHTS

RS SERIES TELESCOPIC HANDLERS



Jobsites demand superior performance. And that's what the RS Series telescopic

handlers provide. Lifting up to 12,000 lbs. (5444 kg) (RS12-42) with lift heights up to 55' (16.8 m) (RS10-55), these machines provide the extra working capacity without sacrificing the comfort and features expected in the RS Series telescopic handlers.

REAR AXLE STABILIZATION – Stabilizer cylinder locks the rear axle to improve stability whenever the boom is raised 60 degrees or the parking brake is applied (not available on RS5-19 and RS6-34).

OUTRIGGERS – Add stability and increase capacity when lifting to full height (not available on RS5-19 and RS6-34).

INTERNAL WET DISC BRAKES – Provide excellent stopping capability and longer life.

HEAVY DUTY BOOMS – Robust boom design can easily handle the 5,500 to 12,000 pound (2495 to 5444 kg) rated loads of the RS Series.

RS SERIES TELESCOPIC HANDLERS

COMPACT CARRY-ALL



5,500 lbs.
(2495 kg)
Lift Capacity

19'1" (5.8 m)
Lift Height

11'0"
(3.35 m)
Turning Radius

Size does matter . . . especially when working on confined jobsites. With a compact stature and tight turning radius, this little giant makes working in limited space easy. Coupled with a high lift height and impressive load capacity, the RS5-19 creates big results, maximizing your investment.

GEHL



BUILT FOR PERFORMANCE –

A double-wall rear tower and robust, heavy-duty boom nose provide the added strength where it is needed most.



EXCELLENT HYDRAULICS

with a flow up to 20 gpm (76 L/min) provide the performance necessary to power a wide variety of attachments.



TWO-SPEED TRANSMISSION

provides high speed for ground travel up to 15 mph (24 km/hr) and a lower speed for extra tractive power.

WHEN SIZE MATTERS



EXTREME MANEUVERABILITY

with a turning radius of just 11 feet (3.35 m) makes working, and turning, in small spaces easy.



WORK COMFORTABLY in a ROPS/FOPS canopy or an optional ROPS/FOPS enclosed cab. Add air-conditioning for a perfect operating climate.



SERVICEABILITY is simple with a large, hinged hood on the side of the machine that lifts out of the way. A hinged door in the belly pan grants access to the oil drain.

SUPERIOR STRENGTH



up to
12,000 lbs.
(5444 kg)
Lift Capacity

34' to 55'
(10.4 to 16.8 m)
Lift Heights

up to
20 mph
(32.5 km/hr)
Travel Speeds

Get endless possibilities with the RS Series Telescopic Handlers. Offering superior load capacity, excellent visibility and tight turning, these machines will provide a great return on investment. And high-quality components provide excellent reliability, reducing downtime and maximizing profitability.

GEHL



OUTRIGGERS increase stability and add to the lift capacity. Optional on the RS6-42, RS8-42, RS8-44, RS10-44 and RS12-42; standard on the RS10-55.



TIGHTER TURNING RADIUS allows the RS Series models to perform on confined jobsites. A tighter turning radius requires less backing up for better efficiency.



BOX-SECTION BOOMS handle capacities up to 12,000 lbs. (5444 kg) on the RS12-42. The RS6-42 can carry its full load of 6,600 lbs. (2994 kg) to its full lift height of 42 feet (12.8 m).

ENDLESS POSSIBILITIES



SELF LEVELING is a standard feature that automatically levels the forks or attachment as the boom is raised. This eliminates the need for manual adjustments.



TRI-FUNCTION JOYSTICK allows the operator to control attachment tilt, auxiliary hydraulics and boom functions with an optional single joystick and speed control knobs.



MAXIMIZE COMFORT with an adjustable armrest and an optional suspension seat. The operator has a full 360 degree view for increased precision and safety. Add air-conditioning* for added comfort.

** Not available on RS6-34*



The RS Series Telescopic Handlers have the features and options available to increase your operation's efficiency and productivity.

STEERING TO SUCCESS – The entire RS Series Telescopic Handler line features selective steering, allowing the operator to choose between three steering modes: four-wheel, two-wheel and crab. Changing modes is as easy as flipping a switch in the operator's station.



2-WHEEL



4-WHEEL



CRAB

GEHL



PERSONNEL WORK PLATFORM (PWP) SYSTEM

The optional Gehl PWP System allows the safe and efficient use of an ANSI/ITSDF B56.6 compliant work platform.

The PWP System makes every job almost as easy as working at ground level. When the system is engaged the transmission is temporarily disconnected, the rear axle stabilizer is engaged, the frame leveling speed is reduced, and the parking brake is applied. A remote shut-off is located on the platform. This increases safety and allows for precise positioning.

PRODUCTIVITY MADE SIMPLE

REMOTE BOOM CONTROL (RBC) SYSTEM

With the RBC System option, a single operator can control boom and engine functions from outside the cab. When placing loads, an operator can leave the cab to control boom functions from a location that has better visibility – even from within a building.

The RBC System is compatible with any ANSI/ITSDF B56.6 compliant work platform and includes all the safety features of the PWP System.





Get the versatility you need to complete the job with a wide variety of attachments. With the RS Series Telescopic Handlers, your operation can do anything from material handling to lifting workers.

HYDRAULIC PERFORMANCE – Excellent auxiliary hydraulic flow and system pressure provide the hydraulic performance needed to power a wide variety of attachments.

SELF-LEVELING – Hydraulic self-leveling lift action automatically keeps the load level as the boom is raised.

PERSONNEL WORK PLATFORM (PWP) SYSTEM – Works with any ANSI/ITSDF B56.6- compliant work platform to increase jobsite safety and versatility.

DYNATTACH® – The Dynattach® Quick-Attach system allows quick attachment changes with unsurpassed ease. The operator leaves the seat only to disengage the attachment.

ENHANCE VERSATILITY



SWING CARRIAGE

90° and 180° swing



LOG AND PIPE

with grapple arms



JIB BOOM

5'0" (1.52 m) with winch and 50'0" (15.24 m) cable
5'0" (1.52 m) with winch and 60'0" (18.29 m) cable



TRUSS BOOM

5'0" (1.52 m) or 8'0" (2.44 m) without winch
12'0" (3.66 m) or 15'0" (4.57 m) with optional winch



PERSONNEL WORK PLATFORMS

90° and 180° swing



ROTATING CARRIAGE

48" (1.22 m) wide
66" (1.68 m) wide



FORK SHIFT

50" (1.27 m) wide



CARRIAGES

Masonry, framing and standard carriages in a variety of widths



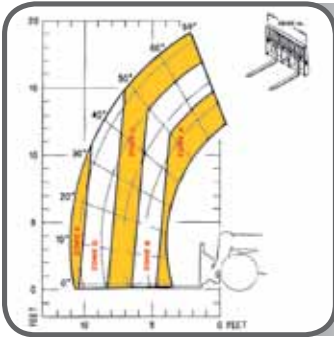

RS5-19

- A** 5,500 lbs. (2495 kg)
- B** 4,000 lbs. (1815 kg)
- C** 3,000 lbs. (1361 kg)
- D** 2,000 lbs. (908 kg)
- E** 1,850 lbs. (840 kg)

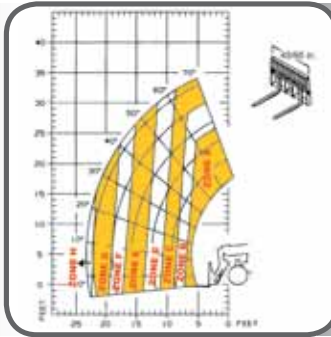

RS6-34

- A** 6,000 lbs. (2722 kg)
- B** 5,000 lbs. (2268 kg)
- C** 4,000 lbs. (1814 kg)
- D** 3,000 lbs. (1361 kg)
- E** 2,000 lbs. (907 kg)
- F** 1,500 lbs. (680 kg)
- G** 1,000 lbs. (454 kg)
- H** 900 lbs. (408 kg)

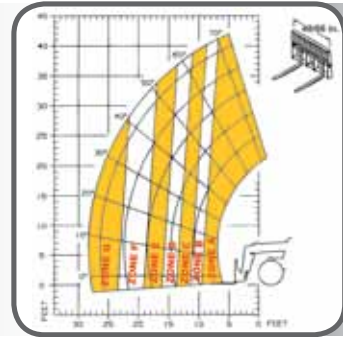

RS6-42

- A** 6,600/6,600 lbs. (2994/2994 kg)
- B** 6,000/6,600 lbs. (2722/2994 kg)
- C** 5,000/6,000 lbs. (2268/2722 kg)
- D** 4,000/4,000 lbs. (1814/1814 kg)
- E** 3,000/4,000 lbs. (1361/1814 kg)
- F** 2,000/4,000 lbs. (907/1814 kg)
- G** 1,000/3,000 lbs. (454/1361 kg)

outriggers up / optional outriggers down

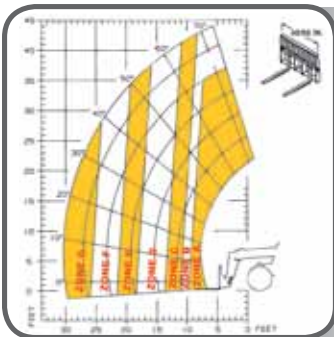

RS8-42

- A** 8,000/8,000 lbs. (3629/3629 kg)
- B** 7,000/8,000 lbs. (3175/3629 kg)
- C** 6,000/8,000 lbs. (2722/3629 kg)
- D** 4,000/6,000 lbs. (1814/2722 kg)
- E** 3,000/4,000 lbs. (1361/1814 kg)
- F** 2,000/4,000 lbs. (907/1814 kg)
- G** 1,000/3,000 lbs. (454/1361 kg)

outriggers up / optional outriggers down

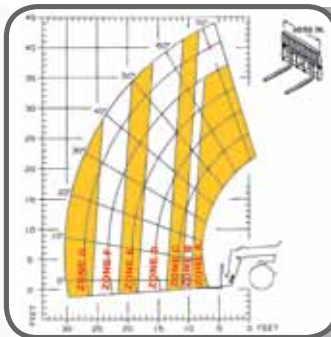

RS8-44

- A** 8,000/8,000 lbs. (3629/3629 kg)
- B** 7,000/8,000 lbs. (3175/3629 kg)
- C** 6,000/8,000 lbs. (2722/3629 kg)
- D** 4,000/6,000 lbs. (1814/2722 kg)
- E** 3,000/4,000 lbs. (1361/1814 kg)
- F** 2,000/4,000 lbs. (907/1814 kg)
- G** 1,000/3,000 lbs. (454/1361 kg)

outriggers up / optional outriggers down

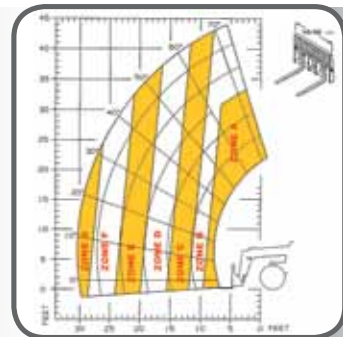

RS10-44

- A** 10,000/10,000 lbs. (4536/4536 kg)
- B** 8,000/8,000 lbs. (3629/3629 kg)
- C** 6,000/8,000 lbs. (2722/3629 kg)
- D** 4,000/6,000 lbs. (1814/2722 kg)
- E** 3,000/6,000 lbs. (1361/2722 kg)
- F** 2,000/4,000 lbs. (907/1814 kg)
- G** 1,500/3,000 lbs. (680/1361 kg)

outriggers up / optional outriggers down



RS10-55
outriggers up

- A** 10,000 lbs. (4536 kg)
- B** 8,000 lbs. (3629 kg)
- C** 6,000 lbs. (2722 kg)
- D** 5,000 lbs. (2268 kg)
- E** 4,000 lbs. (1814 kg)
- F** 3,000 lbs. (1361 kg)
- G** 2,000 lbs. (907 kg)
- H** 1,000 lbs. (454 kg)
- I** 500 lbs. (227 kg)
- J** 250 lbs. (113 kg)

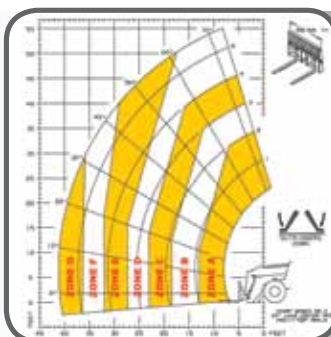

RS10-55
outriggers down

- A** 10,000 lbs. (4536 kg)
- B** 8,000 lbs. (3629 kg)
- C** 6,000 lbs. (2722 kg)
- D** 5,000 lbs. (2268 kg)
- E** 4,000 lbs. (1814 kg)
- F** 3,000 lbs. (1361 kg)
- G** 2,000 lbs. (907 kg)

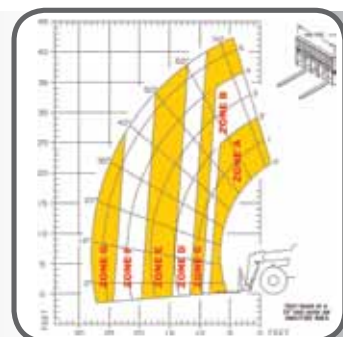

RS12-42

- A** 12,000/12,000 lbs. (5444/5444 kg)
- B** 10,000/10,000 lbs. (4536/4536 kg)
- C** 8,000/8,000 lbs. (3629/3629 kg)
- D** 6,000/8,000 lbs. (2722/3629 kg)
- E** 4,000/6,000 lbs. (1814/2722 kg)
- F** 3,000/5,000 lbs. (1361/2268 kg)
- G** 2,000/4,000 lbs. (907/1814 kg)

outriggers up / optional outriggers down

RS SERIES TELESCOPIC HANDLERS

| | | RS5-19 | RS6-34 | RS6-42 | RS8-42 | RS8-44 | RS10-44 | RS10-55 | RS12-42 | |
|-------------------------------|---|--|----------------------------|----------------------------|----------------------------|----------------------------|----------------------------|----------------------------|----------------------------|--|
| CAPACITIES | Lift Capacity (kg) | 5500 lbs. (2495) | 6000 lbs. (2722) | 6600 lbs. (2994) | 8000 lbs. (3629) | 8000 lbs. (3629) | 10,000 lbs. (4536) | 10,000 lbs. (4536) | 12,000 lbs. (5444) | |
| | Maximum Lift Height (m) | 19'1" (5.8) | 34'3" (10.4) | 42'0" (12.8) | 42'0" (12.8) | 44'0" (13.4) | 44'0" (13.4) | 55'1" (16.8) | 42'0" (12.8) | |
| | Capacity at Maximum Lift Height (kg) | 3000 lbs. (1361) | 4000 lbs. (1815) | 6600 lbs. (2994) | 7000 lbs. (3176) | 7000 lbs. (3176) | 8000 lbs. (3629) | 5000* lbs. (2268) | 8000 lbs. (3629) | |
| | Maximum Forward Reach (m) | 11'0" (3.4) | 23'3" (7.0) | 28'3" (8.6) | 28'3" (8.6) | 30'5" (9.3) | 30'5" (9.3) | 41'2" (12.6) | 27'11" (8.5) | |
| | Capacity at Max. Forward Reach (kg) | 1850 lbs. (840) | 900 lbs. (409) | 1000 lbs. (454) | 1000 lbs. (454) | 1000 lbs. (454) | 1500 lbs. (687) | 2000 lbs. (908) | 2000 lbs. (908) | |
| | Max. Reach Below Grade (mm) | 0" (0) | 24" (610) | 14" (356) | 14" (356) | 16" (406) | 16" (406) | 29" (737) | 14" (355.6) | |
| ENGINE | Manufacturer | Yanmar | John Deere | John Deere | John Deere | John Deere | John Deere | John Deere | John Deere | |
| | Power (kW) | 69 hp (50.1) | 74 hp (55) | 115 hp (86) | 115 hp (86) | 115 hp (86) | 115 hp (86) | 115 hp (86) | 115 hp (86) | |
| | Aspiration | Natural | Turbocharged | Turbocharged | Turbocharged | Turbocharged | Turbocharged | Turbocharged | Turbocharged | |
| | Model | 4TNV98C Tier IV | 4045T Interim Tier IV | 4045T Interim Tier IV | 4045T Interim Tier IV | 4045T Interim Tier IV | 4045T Interim Tier IV | 4045T Interim Tier IV | 4045T Interim Tier IV | |
| | Rated Speed | 2500 rpm | 2400 rpm | 2500 rpm | 2500 rpm | 2500 rpm | 2500 rpm | 2500 rpm | 2500 rpm | |
| COMPONENTS | Transmission | Rexroth 2-speed | Dana 3-speed Powershift | Dana 3-speed Powershift | Dana 3-speed Powershift | Dana 3-speed Powershift | Dana 4-speed Powershift | Dana 4-speed Powershift | Dana 4-speed Powershift | |
| | Maximum Travel Speed (km/hr) | 15 mph (24) | 20.2 mph (32.5) | 18.8 mph (30.3) | 18.8 mph (30.3) | 18.8 mph (30.3) | 19.3 mph (31.1) | 19.3 mph (31.1) | 19.3 mph (31.1) | |
| | Selective Steering | 4-wheel 2-wheel Crab | 4-wheel 2-wheel Crab | 4-wheel 2-wheel Crab | 4-wheel 2-wheel Crab | 4-wheel 2-wheel Crab | 4-wheel 2-wheel Crab | 4-wheel 2-wheel Crab | 4-wheel 2-wheel Crab | |
| | Hydraulically Actuated Internal Wet-Disc Brakes | 2-Wheel | 4-Wheel | | | | | | | |
| | Parking Brake | Spring-Applied, Hydraulic Release (SAHR) on Front Axle | | | | | | | | |
| | Axle Manufacturer | Dana | | | | | | | | |
| HYDRAULIC SYSTEM | Pump Type | Gear | | | | | | | | |
| | Total Capacity (L/min) | 20 gpm (76) | 29 gpm (110) | 40 gpm (151) | 40 gpm (151) | 40 gpm (151) | 40 gpm (151) | 40 gpm (151) | 40 gpm (151) | |
| | System Pressure (bar) | 3350 psi (231) | 3000 psi (207) | 3000 psi (207) | 3000 psi (207) | 3000 psi (207) | 3000 psi (207) | 3000 psi (207) | 3000 psi (207) | |
| | Hydraulic Reservoir Capacity (L) | 18 gal. (68) | 35 gal. (133) | 45 gal. (170) | 45 gal. (170) | 45 gal. (170) | 45 gal. (170) | 45 gal. (170) | 45 gal. (170) | |
| GENERAL SPECIFICATIONS | Approximate Weight (kg) | 10,000 lbs. (4536) | 15,100 lbs. (6850) | 22,000 lbs. (9979) | 23,350 lbs. (10591) | 23,500 lbs. (10659) | 25,500 lbs. (11567) | 27,800 lbs. (12610) | 25,200 lbs. (11431) | |
| | Length – Less Forks (m) | 12'4" (3.8) | 16'0" (4.9) | 19'1" (5.8) | 19'1" (5.8) | 19'10" (6.1) | 20'0" (6.1) | 21'0" (6.4) | 19'3" (5.9) | |
| | Width (m) | 5'11" (1.80) | 7'10" (2.4) | 8'0" (2.4) | 8'0" (2.4) | 8'0" (2.4) | 8'3" (2.5) | 8'3" (2.5) | 8'3" (2.5) | |
| | Ground Clearance (mm) | 14" (350) | 14" (350) | 16" (400) | 16" (400) | 16" (400) | 18" (457) | 18" (457) | 18" (457) | |
| | Wheelbase (m) | 7'6" (2.29) | 9'2" (2.8) | 10'0" (3.0) | 10'0" (3.0) | 10'0" (3.0) | 10'0" (3.0) | 10'4" (3.1) | 10'4" (3.1) | |
| | Turning Radius (m) | 11'0" (3.35) | 12'6" (3.8) | 13'8" (4.2) | 13'8" (4.2) | 13'8" (4.2) | 13'10" (4.22) | 13'11" (4.24) | 13'11" (4.24) | |
| | Overall Height (m) | 6'4" (1.93) | 7'10" (2.4) | 7'10" (2.4) | 7'10" (2.4) | 7'10" (2.4) | 7'11" (2.4) | 8'6" (2.6) | 7'11" (2.4) | |
| | Frame Leveling | N/A | ±10° | ±10° | ±10° | ±10° | ±10° | ±10° | ±10° | |
| | Fuel Capacity (L) | 17 gal. (64) | 29 gal. (110) | 47 gal. (178) | 47 gal. (178) | 47 gal. (178) | 47 gal. (178) | 47 gal. (178) | 47 gal. (178) | |

| TIRE OPTIONS | RS5-19 | RS6-34 | RS6-42/RS8-42/RS8-44 | RS10-44/RS10-55/RS12-42 |
|---------------------|-------------------------------------|--------------------------------|--------------------------------|------------------------------|
| | 12.00 x 16.5 Bias/10 PR | 15.00 x 19.5/12 PR | 13.00 x 24/12 PR | 14.00 x 12 PR |
| | 12.00 x 16.5 Bias/10 PR Foam-Filled | 15.00 x 19.5/12 PR Foam-Filled | 13.00 x 24/12 PR - Foam Filled | 14.00 x 24/12 PR Foam-Filled |
| | 12.00 x 16.5 Solid Rubber | 15.00 x 19.5 Solid Rubber | 13.00 x 24/12 PR - Rock | 13.00 x 24 Solid Rubber |
| | | 13.00 x 24 Solid Rubber | | |

* with outriggers down

GEHL
geh.com

West Bend, WI 53095 U.S.A.

Tel: 262-334-9461

Fax: 262-338-7517

 Find us on Facebook
GEHL COMPACT EQUIPMENT

 This product is created from well-managed forests, controlled sources, and contains a minimum of 10% post consumer waste.

For more information on Gehl equipment, call our hotline at

1-800-628-0491

or visit geh.com

Gehl reminds users to read and understand the operator's manual before operating any equipment. Also, make sure all safety devices and shields are in place and functioning properly.

Gehl reserves the right to add improvements or make changes in features and specifications at any time without notice or obligation.