

---

Technical sheet

# **MLT 733-115**

Telehandlers

---



Capacities	Metric	Imperial
Max. capacity	3300 kg	7,200 lbs
Max. lifting height	6.90 m	22 ft 7 in
Max. outreach	3.90 m	12 ft 9 in
Weight and dimensions		
Unladen weight (with forks)	7015 kg	15,465 lbs
m4 - Ground clearance	0.44 m	17 in
l2 - Overall length to carriage	4.85 m	15 ft 1 in
y - Wheelbase	2.81 m	9 ft 2 in
b4 - Overall width of cab	0.95 m	3 ft 1 in
b1 - Overall width	2.39 m	7 ft 10 in
h17 - Overall height	2.38 m	7 ft 9 in
a4 - Crowd angle	13 °	13 °
a5 - Dump angle	134 °	134 °
Wa1 - External turning radius (over tires)	3.92 m	12 ft 1 in
Standard tires	460/70 R24	460/70 R24
Performances		
Lifting	6.75 s	6.75 s
Lowering	5.65 s	5.65 s
Extension	6.50 s	6.50 s
Retraction	3.90 s	3.90 s
Crowd	3.15 s	3.15 s
Dump	2.55 s	2.55 s
Engine		
Brand	Deutz	Deutz
Environmental norm	Stage IV / Tier 4 Final	Stage IV / Tier 4 Final
Model	TCD 3.6 l	TCD 3.6 l
Number of cylinders - Cubic capacity	4 - 3621 cm <sup>3</sup>	4 - 220 in <sup>3</sup>
Power	115 hp / 85 kW	115 hp / 85 kW
Max. torque	410 Nm at 1600 rpm	302 ft.lbs at 1600 rpm
Laden drawbar pull	7380 daN	16,590 lbf
Reversible fan	Standard	Standard
Cooling system	4 radiators (water + intercooler + hydraulic oil + transmission oil)	4 radiators (water + intercooler + hydraulic oil + transmission oil)
Transmission		
Type	Powershuttle	Powershuttle
Number of gears (forward/reverse)	4/4	4/4
Max. travel speed (may vary according to applicable regulations)	32 km/h	20 mph
Differential type	Limited slip differential on front axle	Limited slip differential on front axle
Parking brake	Manual parking brake	Manual parking brake
Service brake	Hydraulic oil immersed multi-disc braking on front & rear axles	Hydraulic oil immersed multi-disc braking on front & rear axles
Hydraulics		
Hydraulic pump type	Gear pump	Gear pump
Hydraulic flow - Pressure	104 l/min - 250 bar	26.41 gpm - 3625.94 psi
Tank capacities		
Hydraulic oil	135 l	36 US gal.
Fuel	120 l	32 US gal.
Diesel Exhaust Fluid (AdBlue® type)	10 l	3 US gal.

Noise & vibration		
Noise at driving position (LpA) tested following NF EN 12053 norm	76 dB	76 dB
Environmental noise LwA	105 dB	105 dB
Vibration to whole hand / arm	<2.5 m/s <sup>2</sup>	<8.2 ft/s <sup>2</sup>
Miscellaneous		
Safety	Tractor homologation EN 15000 Norm Cab ROPS - FOPS Level 2	Tractor homologation EN 15000 Norm Cab ROPS - FOPS Level 2

## Load chart

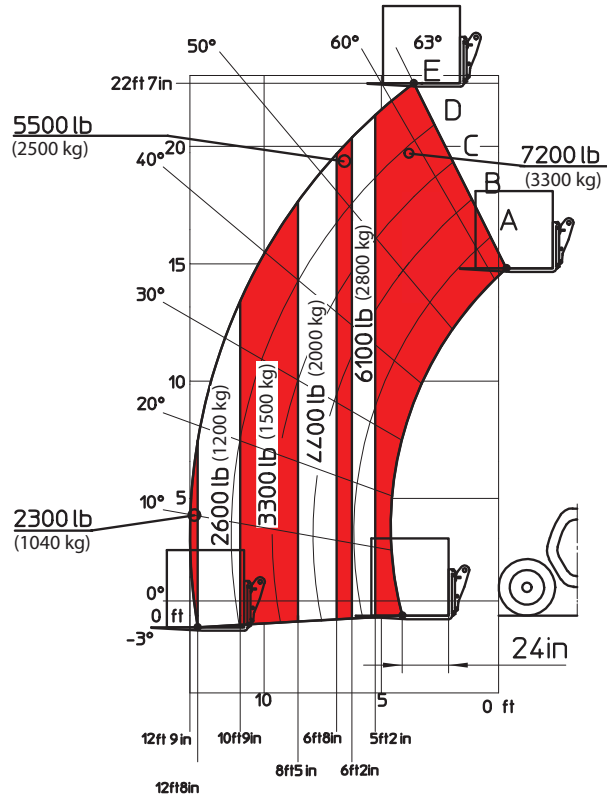

Rough terrain load chart (EN 1459 B)

## Dimensional drawing

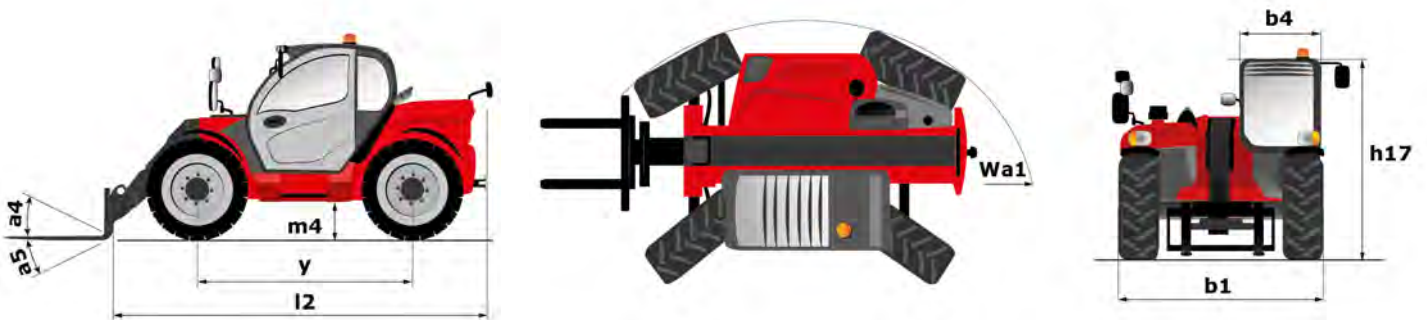

## Options / Finishing

S : Standard / O : Optional / - : Not available

General	
Self cleaning air prefilter	S
Auto reversing fan	S
Boom suspension "Active CRC"	S
Manual towing hitch	S
Comfort	
Air suspension cloth seat (GRAMMER)	S
Bluetooth car radio with integrated microphone (100 W)	S
Manual air conditioning	S
"Harmony" display	S
Hydraulic	
Easy Connect System (ECS)	S
Continuous flow hydraulics	S
Attachment hydraulic locking	S
Return pipe to hydraulic oil tank	O
Electrovalve for 2 hydraulic functions (on boom head)	O
Electricity / Safety	
Audio warning on reverse movements	S
Front and rear LED work lights (x4 : 2 front + 2 rear)	S
Extra front wiper	S
LED work lights on boom head	S



Manitou North America, LLC.

• PO Box 179 • West Bend, WI 53095

Tel: 262-334-9461 • Fax: 262-338-7517

[www.manitou.com](http://www.manitou.com)



This brochure describes versions and configuration options for Manitou products which may be fitted with different equipment. The equipment described in this brochure may be standard, optional or not available depending on version. Manitou reserves the right to change the specifications shown and described at any time and without prior warning. The manufacturer is not liable for the specifications given. For more information, contact your Manitou dealer. Non-contractual document. Product descriptions may differ from actual products. List of specifications is not comprehensive. The logos and visual identity of the company are the property of Manitou and may not be used without authorization. All rights reserved. The photos and diagrams contained in this brochure are provided for information only.

MANITOU BF SA - Limited company with board of directors - Share capital: 39,547,824 euros - 857 802 508 RCS Nantes